



Since 1969

Unnati[®]

MOTORS | PUMPS



50 / 60 Hz



Since 1969
Unnati[®]
MOTORS | PUMPS

COMPANY PROFILE

Incorporated in the year 1985, UNNATI PUMPS PVT. LTD., is a manufacturing more than hundreds different varieties of submersible pump sets customized specially to customers' needs. We market these pumps under the brand name "Unnati" through our wide-spread and extensive distribution network across India and overseas market. We have our corporate and manufacturing set up at 81, Amarnath Industrial Estate, Naroda Road, Ahmedabad – 380025, Gujarat, INDIA.

THE PROMOTER

The Company is promoted and managed by MR. S.B. Patel, a technocrat and qualified entrepreneur having 5 decades of rich experience in pumping technology and marketing.

It is under his leadership, UNNATI PUMPS PVT. LTD. has gathered many feathers on its cap to the extent that UNNATI has become synonymous.

He is now assisted by his versatile son Mr. Dhruvik S. Patel, the Director, to develop and cater overseas and domestic market.

OUR INFRASTRUCTURE

The pump-sets are manufactured with using latest technology in air condition eco-friendly environment using SPM and CNC machines for mass production under the strict supervision of qualified, experienced and expert engineers to maintain the quality and consistent performance of our pump sets.

We have installed, auto welding machine, auto-hydraulic press and online assembly unit for fabricated S.S. Impeller and bowels. We also have computerized printing and marking machines for name plates of pump and motor sets. Submersible pump components are pre-washed by special washing machine prior to the assembly.

Installation of online pump assembly is in progress.

CAD is used to design all the critical components in order to achieve optimum performance.

All equipments are regularly monitored for accuracy and efficiency.

At "UNNATI", we also focus on R&D to study and analyze the products for continuous modification improvement and upgradation for efficiency and performance of the pumpsets and quality enhancement.

TRAINING

The company give utmost importance in imparting training to its employees and distributors not only to handle the job with perfection but also keep them aware of latest development in the field of pump technology.

Company has well developed extensive manufacturing set up to meet any market demand in volume and quality thanks to its technologically advanced facilities.



Satisfied customer is our highest achievement which” keeps us constantly striving to serve our customers with integrity and quality. Focusing on this goal with vigorous team efforts, we promise to serve them to deliver only the best.

In order to maintain the highest quality and performance of our pump sets the company has facility of ultra-modern testing and inspection instruments for continuous monitoring manufacturing process.

We have electronic flow-meter in the computerized testing laboratory which provides unique facility of testing multiple pumps simultaneously for head versus discharge and overall efficiency at various position minimizing the time and human error thus making the performance report more authentic and reliable.





Since 1969
Unnati
MOTORS | PUMPS

CUSTOMER FOCUS

At Unnati, customer is focus of attention for all activities at all level and every care is taken to see him delighted. His enquiry prior to sales is promptly responded for techno-commercial details and after sales-services to develop his confidence in our product and services.

Utmost care is taken to define customer requirements or complaints by providing prompt and proper corrective actions thereby keeping him satisfied. Suggestions and complaints are also invited from the customers periodically to find out whether they are satisfied with the performance of product, timely supplies, packing & dispatch, behavior and attitude and whether they are really satisfied with the corrective actions taken.

An IS/ISO 9001:2015 Company

Unnati Pumps Pvt. Ltd. has privilege to be one of the pioneer manufacturing units of India manufacturing Submersible Pump sets to obtain International Quality System Certification ISO 9001 way back on 15th. August 1995.

THE KEY

to our growth and
success is simple



“ Together we can do it
Together we have
always done it ”



3"

WATER LUBRICATED **SUBMERSIBLE MOTOR**

Unnati UW3 series submersible motors are water Lubricated designed for installation in 3" diameter or larger water wells. These motors operate in Capacitor Start Capacitor Run (CSCR) system and can be easily rewound and repaired.

Unnati Submersible Motors are robust rewindable and pre-filled with clean water mixed with anti-corrosion fluid. The stator winding is of Poly Propylene copper winding wires. It features water lubricated radial and thrust bearings. Dynamically balanced rotor of these Unnati UW3 Series submersible motors maintain uniform clearance to give better efficiency and increase the life cycle of the water lubricated bush bearings. Specially designed high performance thrust bearings are used to withstand high axial thrust loads.

Pressure equalizing rubber diaphragm is provided to guard against pressure and volume variations due to thermal expansion of water inside the motor. Motor is sealed by "O" rings, shaft seals and sand guards to prevent leakage of motor lubricant and ingress of well water, sand and fibre particles in to the motor. Mounting dimension of motors are in accordance with "NEMA" standard.



PRODUCT SPECIFICATION

- Rewindable
- Upper & Lower Housing and motor base : Graded C.I Casting with Epoxy paint.
- Stator shell : Stainless Steel
- Motor shaft : S S 420
- Winding wire : Poly Propylene
- Degree of protection : IP 68
- Max water temperature : 35° C
- Nos. of Start per Hour : Max 20 at regular intervals.
- Voltage variation : +6% / -10% at rated voltage.
- Bearing : Water lubricated radial and thrust bearing.
- Max depth immersion : 100 metres.
- Motor cable length : 3.0 metres (3 core / 4 core)
- Single phase motor Capacitor Start Capacitor Run (CSCR)
- Power Range : 0.37 to 1.10 kW Single Phase
- Versions :
- A.C. Single Phase : 220-230 Volt / 50 Hz
- Speed : 2850 RPMZ

PRODUCT FEATURE

- Unnati UW3 Water Lubricated Submersible Motor are robust rewindable and pre-filled with clean water mixed with anti-corrosion fluid.
- Shaft extension made of Stainless Steel AISI 420.
- High efficiency electrical design for lower operating cost
- Pressure compensation diaphragm.
- All single phase motors require control box.

PRODUCT APPLICATION

“Unnati” prime mover Submersible Motors are suitable to couple with deep well Submersible Pump used for :

- Residential Purpose
- Fountains
- Pressure Boosting Units
- Gardens & Horticulture





**WATER LUBRICATED
SUBMERSIBLE MOTOR**

SR. NO.	DESCRIPTION	QTY.
1	MOTOR BASE	1
2	BREATHER DIAPHRAGM	1
3	ROCKER SUPPORT	1
4	THRUST BEARING	1
5	LOWER BEARING HOUSING	1
6	BEARING BUSH	4
7	STATOR STAMPING	AS PER S.L.
8	STATOR TUBE	1
9	ROTOR	1
10	UPPER BEARING HOUSING	1
11	S.S. STUD	4
12	INSULATED WINDING WIRE	

Model	Pn		Motor Length (mm)	Net Weight (kg)
	kW	HP		
UW3SP0050H5CI	0.37	0.50	397	8
UW3SP0075H5CI	0.55	0.75	457	9
UW3SP0100H5CI	0.75	1.00	522	11
UW3SP0150H5CI	1.10	1.50	622	13

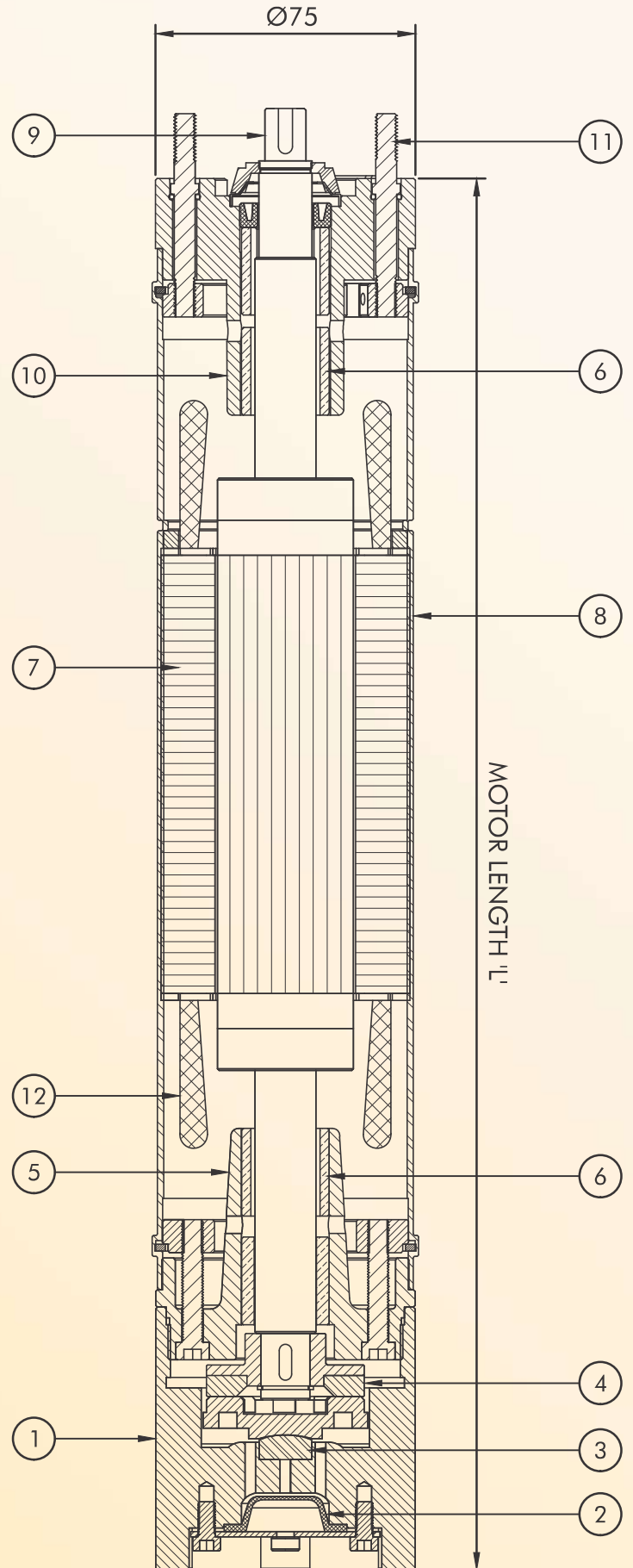

Pn = Rated Output

